

# High-Performance RF Semiconductor Components for 4G and 5G Infrastructure



5G promises very high-speed data transfer rates, much lower latency and greater capability to handle a vast amount of data and a massive number of connected devices. Network providers are required to build wireless infrastructures that are capable to meet these requirements, at a low cost. At the RF components level, arQana Technologies strives to develop components that offer wide bandwidth, high power efficiency and high linearity, providing engineers with design flexibility. Also, arQana offers highly integrated and efficient Front-End Modules that help to reduce system size and design complexity, accelerating time to market and lowering both costs of system and operations.

For Sub-6 GHz bands, arQana is developing Power Amplifiers (PA), Driver Amplifiers (DA), Switches and Front-End Modules (FEM) at different frequency bands.

For 5G Millimeter Wave (mmWave) applications arQana is designing Beamforming ICs (BFIC), and integrated Front-End Modules (FEM).

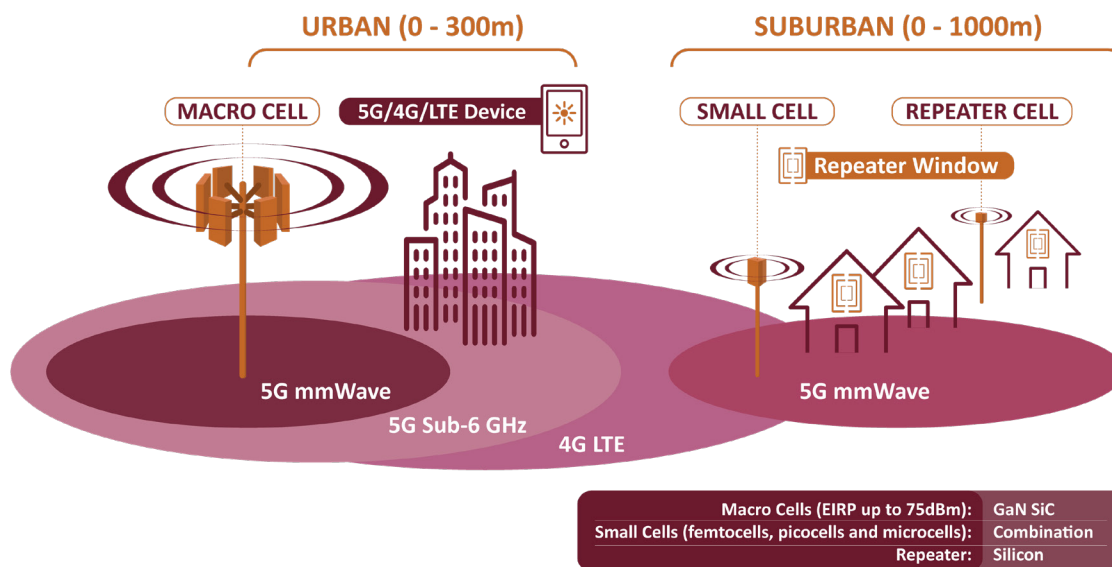

## Rich ecosystem of multiple technologies and solutions

With 5G, there are multiple architectures, use cases and network solutions. We will observe the coexistence of 4G/LTE together with 5G Sub-6 GHz and 5G mmWave networks.

## Small Cells will gain more relevance in 5G

Small Cells enable Mobile Network Operators to deploy sites in strategic locations offering network densification with higher capacities, using licensed and unlicensed wireless spectrum.

## Phased Arrays will be widely adopted in 5G NR FR2

Phased Arrays technologies with beamforming capability will be specifically used to solve the mmWave technical challenges.

### Taiwan arQana Technologies Limited

Bldg. H, 9F., No. 3-2, Park St., Nangang Dist., Taipei City 115, Taiwan (R.O.C.)

T: +886 2 2785 1339 E: sales@arqana-tech.com  
arQana-tech.com

### DISCLAIMER

All Rights Reserved. Copyright ©2021 Taiwan arQana Technologies Limited. All information in this document is provided in connection with arQana Technologies ("arQana") products as a service to its customers and may be used by the customer for informational purposes only. arQana assumes no responsibility for errors or omissions in this information contained and arQana may change its documentation, products, specifications or product descriptions at any time, without prior notice.

# New Family of Products for 4G LTE & 5G NR FR1 Sub-6 GHz

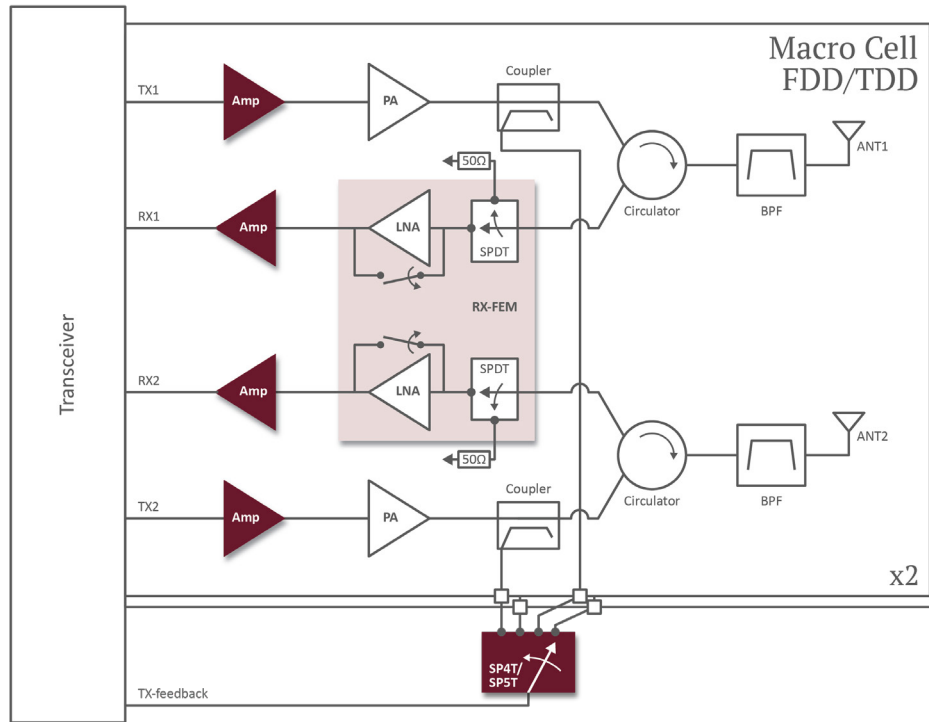

Macro Cell Block Architecture

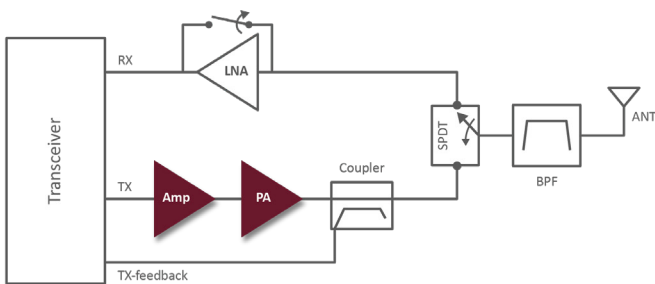

Small Cell TDD  
Block Architecture

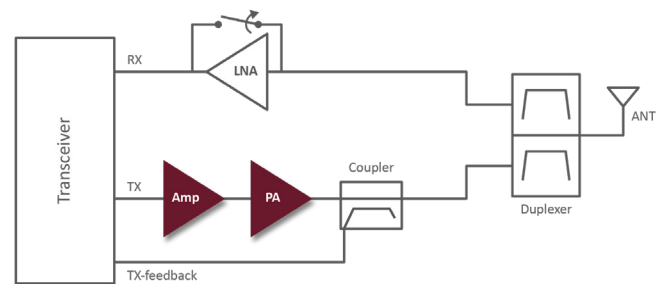

Small Cell FDD  
Block Architecture

■ ■ Coloured products are being developed by arQana

**Taiwan arQana Technologies Limited**

Bldg. H, 9F, No. 3-2, Park St., Nangang Dist.,  
Taipei City 115, Taiwan (R.O.C.)

T: +886 2 2785 1339 E: sales@arqana-tech.com

[arQana-tech.com](http://arQana-tech.com)

**DISCLAIMER**

All Rights Reserved. Copyright ©2021 Taiwan arQana Technologies Limited. All information in this document is provided in connection with arQana Technologies ("arQana") products as a service to its customers and may be used by the customer for informational purposes only. arQana assumes no responsibility for errors or omissions in this information contained and arQana may change its documentation, products, specifications or product descriptions at any time, without prior notice.



## Power Amplifiers: High Efficiency DPD-Friendly

### ARQSP1819-4

1.8 GHz to 1.9 GHz  
Gain = 37 dB  
Psat = 36 dBm  
PAE = 32%  
V<sub>CC</sub> = 5.0 V

- High Efficiency 4W Power Amplifier
- Fully matched (50 Ω input/output)
- High linearity
- Excellent input and output return loss
- Pin-to-pin compatible PA family for 3GPP 5G NR FR1
- Compact package size: 5.0 x 5.0 x 1.1 mm<sup>3</sup>



### ARQSP2122-4

2.1 GHz to 2.2 GHz  
Gain = 38 dB  
Psat = 36.2 dBm  
PAE = 32%  
V<sub>CC</sub> = 5.0 V

- High Efficiency 4W Power Amplifier
- Fully matched (50 Ω input/output)
- High linearity
- Excellent input and output return loss
- Pin-to-pin compatible PA family for 3GPP 5G NR FR1
- Compact package size: 5.0 x 5.0 x 1.1 mm<sup>3</sup>



### ARQSP3336-4

3.3 GHz to 3.6 GHz  
Gain = 38 dB  
Psat = 35 dBm  
PAE = 25%  
V<sub>CC</sub> = 5.0 V

- High Efficiency 4W Power Amplifier
- Fully matched (50 Ω input/output)
- High linearity
- Excellent input and output return loss
- Pin-to-pin compatible PA family for 3GPP 5G NR FR1
- Compact package size: 5.0 x 5.0 x 1.1 mm<sup>3</sup>

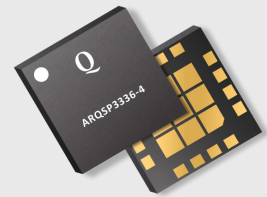

### ARQSP3337-4

3.3 GHz to 3.7 GHz  
Gain = 38 dB  
Psat = 35 dBm  
PAE = 25%  
V<sub>CC</sub> = 5.0 V

- High Efficiency 4W Power Amplifier
- Fully matched (50 Ω input/output)
- High linearity
- Excellent input and output return loss
- Pin-to-pin compatible PA family for 3GPP 5G NR FR1
- Compact package size: 5.0 x 5.0 x 1.1 mm<sup>3</sup>

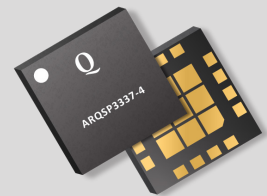

### ARQSP4450-4

4.4 GHz to 5.0 GHz  
Gain = 35 dB  
Psat = 35.5 dBm  
PAE = 25%  
V<sub>CC</sub> = 5.0 V

- High Efficiency 4W Power Amplifier
- Fully matched (50 Ω input/output)
- High linearity
- Excellent input and output return loss
- Pin-to-pin compatible PA family for 3GPP 5G NR FR1
- Compact package size: 5.0 x 5.0 x 1.1 mm<sup>3</sup>

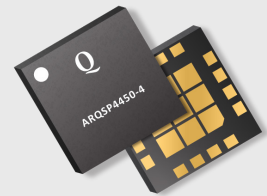

### Taiwan arQana Technologies Limited

Bldg. H, 9F., No. 3-2, Park St., Nangang Dist.,  
Taipei City 115, Taiwan (R.O.C.)

T: +886 2 2785 1339 E: sales@arqana-tech.com

[arQana-tech.com](http://arQana-tech.com)

### DISCLAIMER

All Rights Reserved. Copyright ©2021 Taiwan arQana Technologies Limited. All information in this document is provided in connection with arQana Technologies ("arQana") products as a service to its customers and may be used by the customer for informational purposes only. arQana assumes no responsibility for errors or omissions in this information contained and arQana may change its documentation, products, specifications or product descriptions at any time, without prior notice.



## Rx Dual-Channel Front-End Modules

### ARQSF2442-RX-A

2.4 GHz to 4.2 GHz  
 High Gain = 36 dB  
 Low Gain = 16 dB  
 Noise Figure = 1.3 dB  
 $V_{DD} = 5.0 V$

- Dual-Channel Front-End Module
- High power handling
- Low current consumption in power down mode
- Excellent linearity
- Package size: 6.0 x 6.0 x 0.85 mm<sup>3</sup>



## Switches

### ARQSS1050-5T

1 GHz to 5 GHz  
 Insertion Loss: < 0.7 dB  
 Return Loss: > 20 dB  
 Isolation: > 65 dB  
 $V_{DD} = 3 - 6 V$

- Silicon SP5T Switch
- High power handling
- Fast switching time
- Very low current consumption
- 3.3 V or 1.8 V compatible control logic
- Package size: 4.0 x 4.0 x 0.75 mm<sup>3</sup>



### ARQSS1050-4T

1 GHz to 5 GHz  
 Insertion Loss: < 0.7 dB  
 Return Loss: > 20 dB  
 Isolation: > 65 dB  
 $V_{DD} = 3 - 6 V$

- Silicon SP4T Switch
- High power handling
- Fast switching time
- Very low current consumption
- 3.3 V or 1.8 V compatible control logic
- Package size: 4.0 x 4.0 x 0.75 mm<sup>3</sup>

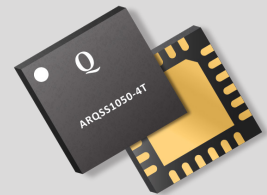

### Taiwan arQana Technologies Limited

Bldg. H, 9F., No. 3-2, Park St., Nangang Dist.,  
 Taipei City 115, Taiwan (R.O.C.)

**T:** +886 2 2785 1339 **E:** sales@arqana-tech.com

**arQana-tech.com**

### DISCLAIMER

All Rights Reserved. Copyright ©2021 Taiwan arQana Technologies Limited. All information in this document is provided in connection with arQana Technologies ("arQana") products as a service to its customers and may be used by the customer for informational purposes only. arQana assumes no responsibility for errors or omissions in this information contained and arQana may change its documentation, products, specifications or product descriptions at any time, without prior notice.



## D2SE Driver Amplifiers

### ARQSD1721-D2S

1.7 GHz to 2.1 GHz  
Noise figure: NF = 2.4 dB  
Linearity: OIP3 = 33 dBm  
Power: OP1dB = 19 dBm  
 $V_{DD} = 3.3 - 5 V$

- Differential To Single-Ended Gain Amplifier
- High and flat gain
- Excellent return loss
- Low drain current
- Power down mode
- Package size: 2.0 x 2.0 x 0.75 mm<sup>3</sup>

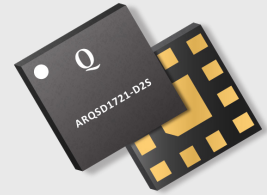

### ARQSD2328-D2S

2.3 GHz to 2.8 GHz  
Noise figure: NF = 2.6 dB  
Linearity: OIP3 = 32 dBm  
Power: OP1dB = 19 dBm  
 $V_{DD} = 3.3 - 5 V$

- Differential To Single-Ended Gain Amplifier
- High and flat gain
- Excellent return loss
- Low drain current
- Power down mode
- Package size: 2.0 x 2.0 x 0.75 mm<sup>3</sup>

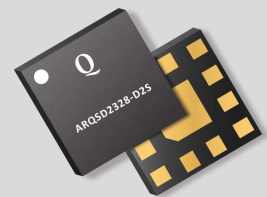

### ARQSD3338-D2S

3.3 GHz to 3.8 GHz  
Noise figure: NF = 2.7 dB  
Linearity: OIP3 = 30 dBm  
Power: OP1dB = 18 dBm  
 $V_{DD} = 3.3 - 5 V$

- Differential To Single-Ended Gain Amplifier
- High and flat gain
- Excellent return loss
- Low drain current
- Power down mode
- Package size: 2.0 x 2.0 x 0.75 mm<sup>3</sup>

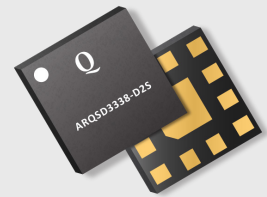

### ARQSD4450-D2S

4.4 GHz to 5.0 GHz  
Noise figure: NF = 3.6 dB  
Linearity: OIP3 = 27 dBm  
Power: OP1dB = 17 dBm  
 $V_{DD} = 3.3 - 5 V$

- Differential To Single-Ended Gain Amplifier
- High and flat gain
- Excellent return loss
- Low drain current
- Power down mode
- Package size: 2.0 x 2.0 x 0.75 mm<sup>3</sup>

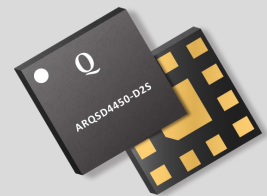

### Taiwan arQana Technologies Limited

Bldg. H, 9F., No. 3-2, Park St., Nangang Dist.,  
Taipei City 115, Taiwan (R.O.C.)

T: +886 2 2785 1339 E: sales@arqana-tech.com

[arQana-tech.com](http://arQana-tech.com)

### DISCLAIMER

All Rights Reserved. Copyright ©2021 Taiwan arQana Technologies Limited. All information in this document is provided in connection with arQana Technologies ("arQana") products as a service to its customers and may be used by the customer for informational purposes only. arQana assumes no responsibility for errors or omissions in this information contained and arQana may change its documentation, products, specifications or product descriptions at any time, without prior notice.



## SE2D Driver Amplifiers

### ARQSD1721-S2D

1.7 GHz to 2.1 GHz  
 Noise figure: NF = 1.5 dB  
 Linearity: OIP3 = 31 dBm  
 Power: OP1dB = 17.5 dBm  
 $V_{DD} = 3.3 - 5 V$

- Single-Ended To Differential Gain Amplifier
- High and flat gain
- Excellent return loss
- Low drain current
- Power down mode
- Package size:  $2.0 \times 2.0 \times 0.75 \text{ mm}^3$



### ARQSD2328-S2D

2.3 GHz to 2.8 GHz  
 Noise figure: NF = 1.6 dB  
 Linearity: OIP3 = 30 dBm  
 Power: OP1dB = 17.5 dBm  
 $V_{DD} = 3.3 - 5 V$

- Single-Ended To Differential Gain Amplifier
- High and flat gain
- Excellent return loss
- Low drain current
- Power down mode
- Package size:  $2.0 \times 2.0 \times 0.75 \text{ mm}^3$



### ARQSD3338-S2D

3.3 GHz to 3.8 GHz  
 Noise figure: NF = 1.8 dB  
 Linearity: OIP3 = 29 dBm  
 Power: OP1dB = 17 dBm  
 $V_{DD} = 3.3 - 5 V$

- Single-Ended To Differential Gain Amplifier
- High and flat gain
- Excellent return loss
- Low drain current
- Power down mode
- Package size:  $2.0 \times 2.0 \times 0.75 \text{ mm}^3$



### ARQSD4450-S2D

4.4 GHz to 5.0 GHz  
 Noise figure: NF = 2.0 dB  
 Linearity: OIP3 = 25 dBm  
 Power: OP1dB = 15.8 dBm  
 $V_{DD} = 3.3 - 5 V$

- Single-Ended To Differential Gain Amplifier
- High and flat gain
- Excellent return loss
- Low drain current
- Power down mode
- Package size:  $2.0 \times 2.0 \times 0.75 \text{ mm}^3$

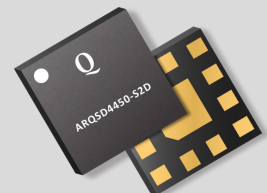

### Taiwan arQana Technologies Limited

Bldg. H, 9F., No. 3-2, Park St., Nangang Dist.,  
 Taipei City 115, Taiwan (R.O.C.)

T: +886 2 2785 1339 E: sales@arqana-tech.com

[arQana-tech.com](http://arQana-tech.com)

### DISCLAIMER

All Rights Reserved. Copyright ©2021 Taiwan arQana Technologies Limited. All information in this document is provided in connection with arQana Technologies ("arQana") products as a service to its customers and may be used by the customer for informational purposes only. arQana assumes no responsibility for errors or omissions in this information contained and arQana may change its documentation, products, specifications or product descriptions at any time, without prior notice.

## Evaluation Boards: Availability

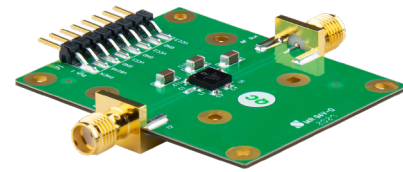

### Power Amplifiers

P/N	Status	EVB	Type	Frequency Range (GHz)	Supply Voltage (V)	Peak Output Power (W)	Package Size (mm <sup>2</sup> )
ARQSP1819-4-EVB	Engineering	Now Available	HPA	1.8 - 1.9	5.0	4	5 x 5
ARQSP2122-4-EVB	Engineering	Now Available	HPA	2.1 - 2.2	5.0	4	5 x 5
ARQSP3336-4-EVB	Engineering	Now Available	HPA	3.3 - 3.6	5.0	4	5 x 5
ARQSP3337-4-EVB	Engineering	from June 2021	HPA	3.3 - 3.7	5.0	4	5 x 5
ARQSP4450-4-EVB	Engineering	from June 2021	HPA	4.4 - 5.0	5.0	4	5 x 5

### Driver Amplifiers

P/N	Status	EVB	Type	Frequency Range (GHz)	Supply Voltage (V)	OP1dB (dBm)	Package Size (mm <sup>2</sup> )
ARQSD1721-D2S-EVB	Engineering	Now Available	D2SE	1.7 - 2.1	3.3 - 5.0	19.0	2 x 2
ARQSD2328-D2S-EVB	Engineering	Now Available	D2SE	2.3 - 2.8	3.3 - 5.0	19.0	2 x 2
ARQSD3338-D2S-EVB	Engineering	Now Available	D2SE	3.3 - 3.8	3.3 - 5.0	18.0	2 x 2
ARQSD4450-D2S-EVB	Engineering	Now Available	D2SE	4.4 - 5.0	3.3 - 5.0	17.0	2 x 2
ARQSD1721-S2D-EVB	Engineering	Now Available	SE2D	1.7 - 2.1	3.3 - 5.0	17.5	2 x 2
ARQSD2328-S2D-EVB	Engineering	Now Available	SE2D	2.3 - 2.8	3.3 - 5.0	17.5	2 x 2
ARQSD3338-S2D-EVB	Engineering	Now Available	SE2D	3.3 - 3.8	3.3 - 5.0	17	2 x 2
ARQSD4450-S2D-EVB	Engineering	Now Available	SE2D	4.4 - 5.0	3.3 - 5.0	15.8	2 x 2

### Rx Front-End Modules

P/N	Status	EVB	Type	Frequency Range (GHz)	Supply Voltage (V)	NF (dB)	Package Size (mm <sup>2</sup> )
ARQSF2442-RX-A-EVB	Engineering	from May 2021	Dual Rx FEM	2.4 - 4.2	5.0	1.3	6 x 6

### Switches

P/N	Status	EVB	Type	Frequency Range (GHz)	Supply Voltage (V)	Insertion Loss (dB)	Package Size (mm <sup>2</sup> )
ARQSS1050-5T-EVB	Engineering	Now Available	SP5T Switch	1.0 - 5.0	3.0 - 6.0	< 0.7	4 x 4
ARQSS1050-4T-EVB	Engineering	Now Available	SP4T Switch	1.0 - 5.0	3.0 - 6.0	< 0.7	4 x 4

#### Taiwan arQana Technologies Limited

Bldg. H, 9F, No. 3-2, Park St., Nangang Dist.,  
Taipei City 115, Taiwan (R.O.C.)

**T:** +886 2 2785 1339 **E:** sales@arqana-tech.com

**arQana-tech.com**

#### DISCLAIMER

All Rights Reserved. Copyright ©2021 Taiwan arQana Technologies Limited. All information in this document is provided in connection with arQana Technologies ("arQana") products as a service to its customers and may be used by the customer for informational purposes only. arQana assumes no responsibility for errors or omissions in this information contained and arQana may change its documentation, products, specifications or product descriptions at any time, without prior notice.

